

Air Heat Burners

Series RAH and TAH-R
For Recirculating Air

Version 1

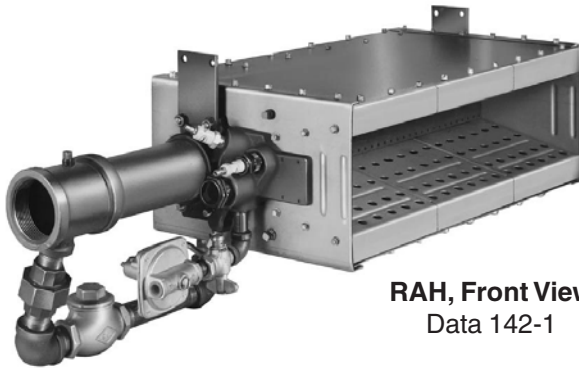

RAH, Front View
Data 142-1

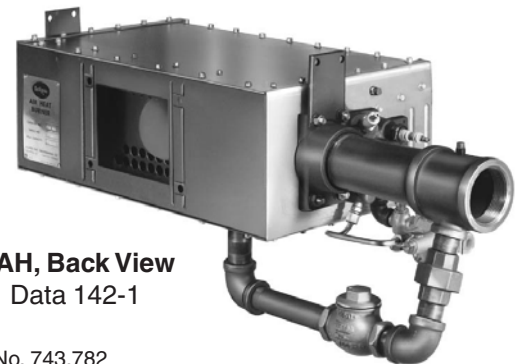

RAH, Back View
Data 142-1

U.S. Reissue Pat. No. 26,244 Canadian Pat. No. 743,782

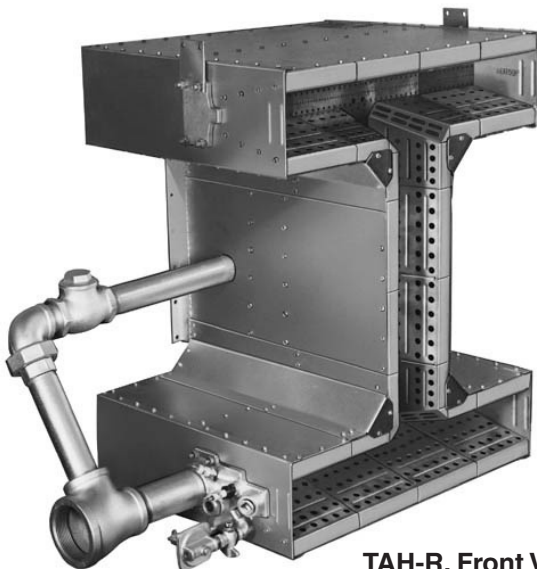

TAH-R, Front View
Data 142-2

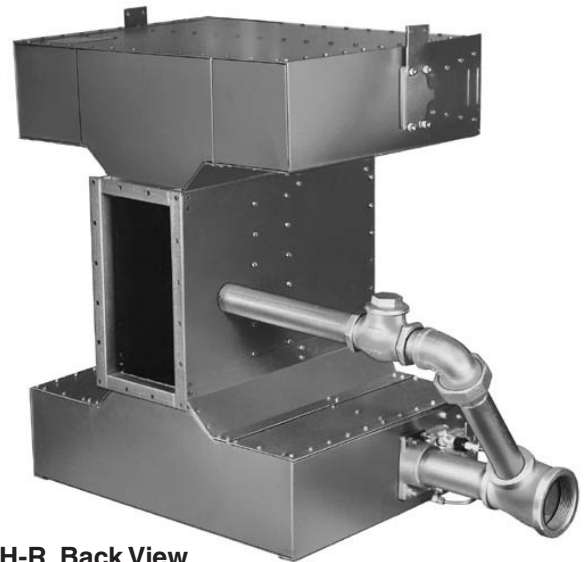

TAH-R, Back View
Data 142-2

WARNING

The burners covered in this Guide are designed to mix fuel with air and burn the resulting mixture. All fuel burning devices are capable of producing explosions and fires when improperly applied, installed, adjusted, controlled, or maintained. This Guide will provide information for using these burners for their limited design purpose. Do not deviate from any instructions or application limits in this Guide without written advice from Eclipse Inc. in Rockford, Illinois. Read this entire Guide before attempting to light burners. If you do not understand any part of the information in this Guide, contact your local Eclipse representative or Eclipse Combustion before proceeding further.

Important Notices About Safe Burner Operation

Storage	Store the burner inside. Exposure to the elements can damage the burner.
Qualifications	Adjustment, maintenance, and troubleshooting of the mechanical parts of this unit should be done by people with good mechanical aptitude and experience with combustion equipment.
Replacement Parts	Order replacement parts from Eclipse only. Any customer-supplied valves or switches should carry UL, FM, CSA, and/or CGA approval where applicable.
Operator Training	The best safety precaution is an alert and competent operator. Thoroughly instruct new operators so they demonstrate an adequate understanding of the equipment and its operation. Regular retraining must be scheduled to maintain a high degree of proficiency. The operator must have easy access to this Information Guide at all times.

1.0 Burner Operating Parameters & Requirements

Applications	Eclipse Air Heat Burners are line type burners ideal for generating large volumes of clean, hot air. Applications include ovens, dryers, fume incinerators, and similar industrial equipment. Combustion air is supplied to "RAH" and "TAH-R" models by a blower located outside the duct. This allows the burners to operate in recirculating airstreams with air temperatures upstream of the burner as high as 750° F (400° C).
Capacities & Supply Pressures	See Figure 2.
Burner Environment	Weather Protection: Protect burners from the weather. Combustion Air: Must be free of contaminants. Eclipse strongly recommends use of a combustion air filter to remove airborne particles. If corrosive fumes or materials are present in the air, supply the blower with fresh, clean air from an uncontaminated area of the plant. Room Openings: If the burner is mounted on the side of the duct, provide at least one square inch of opening to the outdoors for every 4000 Btu/hr (1.2 kW) of burner firing rate. This will admit fresh combustion air. Access: Provide access to the burner for inspection and maintenance.

Figure 1—Ignition, Flame Monitoring, and Pilot Components

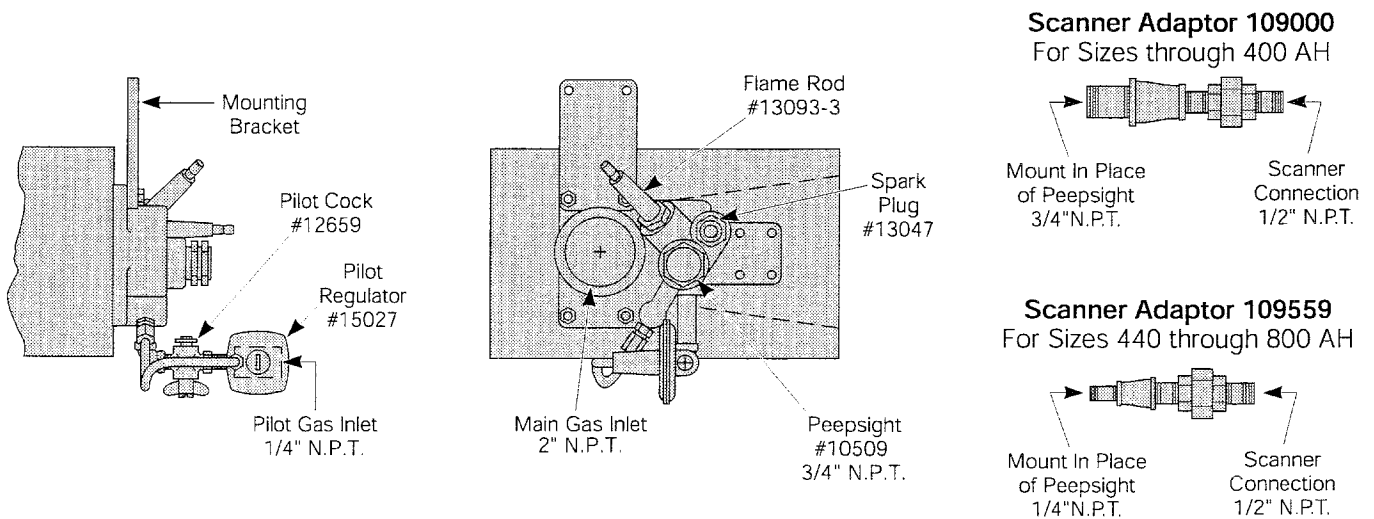

Specifications

Input:	1,000,000 Btu/hr. per lineal foot (962 kW/m).		
Fuels:	Natural gas or 100% propane vapor. Call Eclipse for information on using other fuels.		
Gas Turndown:	40:1		
Pilot Input:	Approximately 25,000 Btu/hr. (7.3 kW)		
Gas Inlet Pressure:	800,000 Btu/hr/ft. (769 kW/m):	Nat. Gas: 2.2" w.c.	5.5 mbar
		Propane: 0.9" w.c.	2.2 mbar
	1,000,000 Btu/hr/ft. (962 kW/m):	Nat. Gas: 3.5" w.c.	8.7 mbar
		Propane: 1.3" w.c.	3.2 mbar
Gas pressure shown is a differential measured between the gas inlet and a tap on the duct wall 10" to 20" (254 to 508 mm) downstream of the burner.			
Flame Length*:	800,000 Btu/hr. (769 kW/m):	28"	0.71 m
	1,000,000 Btu/hr. (962 kW/m):	46"	1.17 m
Piloting:	Integral spark-ignited pilot; ignition plug included.		
Flame Monitoring:	<p>Flame rod supplied. UV scanner adaptors are available. For UV scanners, Eclipse recommends a flame monitoring system that terminates the ignition spark and proves the pilot flame without spark prior to opening the main gas valves.</p> <p>CGA requires two flame rods on burners over 36" long (914 mm). Use a flame monitoring endplate (see Data 140-6) to mount a second flame rod on the end opposite the gas inlet.</p>		
Materials:	All portions of the burner exposed to flame are cast iron or #321 stainless steel.		
Emissions:	Emissions performance depends not only on the burner, but also other factors such as chamber temperature, chamber design, and heat loading. For estimates of emissions performance in your application, call Eclipse.		
Packaging Options:	Available with complete valve trains and control systems. RAH burners and systems can be supplied mounted on duct sections as specified by the customer. Call Eclipse for information on custom packaged systems.		
Models:	Model	Description	Data Sheet
	RAH	Line-shape	Data 142-1
	TAH-R	"I"-shape	Data 142-2

* Based on parallel air flow. If mounted in a cross flow, then flame will be shorter.

CAUTION: It is dangerous to use any fuel burning equipment unless it is equipped with suitable flame sensing devices and automatic fuel shut-off valves. Eclipse can supply such equipment or information on alternate sources.

2.0 Control System Requirements

Turndown Method	Input is normally controlled by a motorized butterfly valve in the gas line to the burner.
Regulator Loading Lines	Connect the top diaphragm chambers of the main gas and pilot gas regulators to the duct approximately 10" downstream of the burner. This will allow the regulators to maintain a constant supply pressure to the burner regardless of varying pressures in the duct.
Piloting	Pilot gas flow is adjusted as shown in Figure 6.
Ignition	Ignition voltage should be 6000 VAC.
Check Valve	See Figure 3. At high fire, the gas pressure at the burner inlet is higher than the air pressure, and the check valve is closed. At low fire, gas pressure falls below the air pressure, and the check valve opens, permitting a small amount of air to mix with the gas. This premix at low fire stabilizes the flame and helps distribute the flame evenly down the length of the burner.
Air Damper	Install an air damper at the combustion air blower inlet, or between the blower and the burner to allow adjustment of combustion air flow.



Warning

Do not install any valve or controlling device in the gas line between the burner and the check valve tee, Figure 3. Because this section of the gas line carries a partial premix at low fire, it is possible under unusual conditions for the flame to travel back through the pipe to the tee. Devices installed in this section may be damaged and may melt, releasing gas to the atmosphere and causing fires or explosions.

Pressure Switch Connection	See Figure 4 for typical connection of combustion air and circulating fan limit switches.
Limit Controls & Safety Equipment	Limit controls and safety equipment should comply with current NFPA Standards* 86 and 86C, and all applicable local codes and/or standards. *Available from: National Fire Protection Association Battery March Park Quincy, MA 02269 American National Standard Institute 1430 Broadway New York, New York 10018

Figure 3–Check Valve Operation

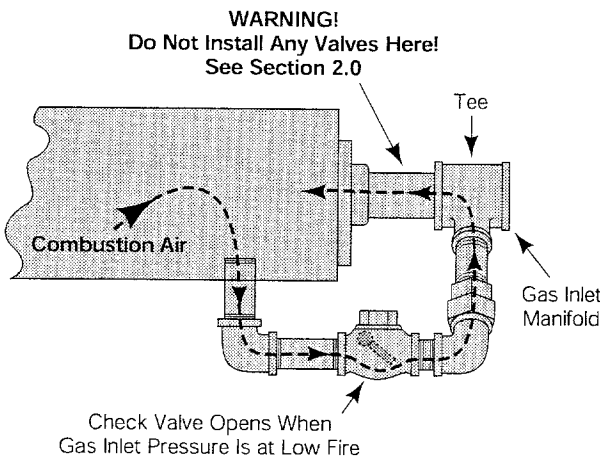

Figure 4–Pressure Switch Location

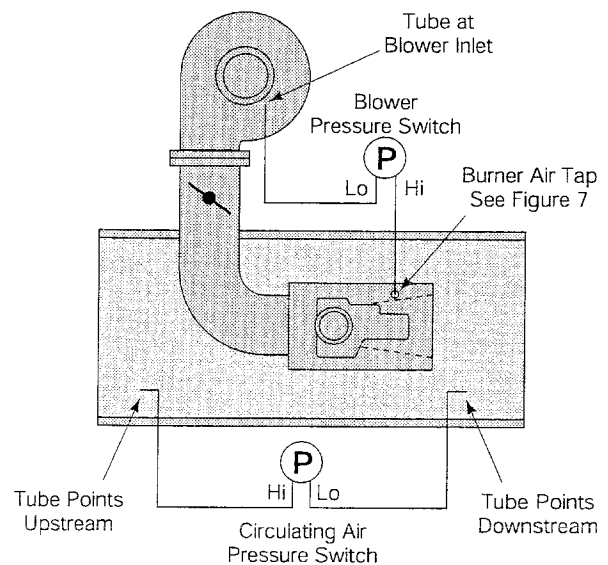
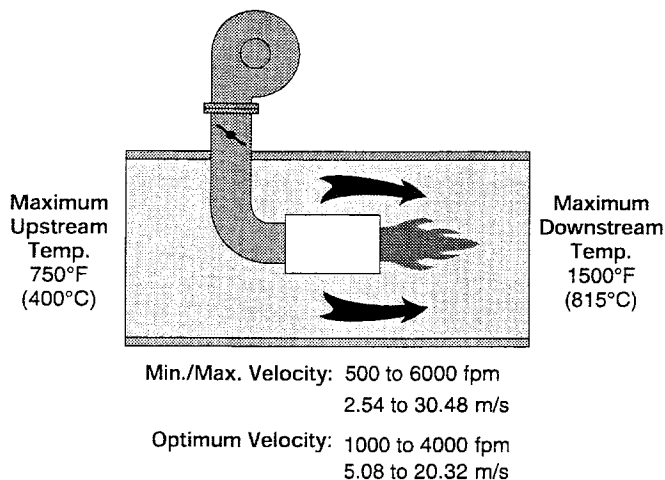

Figure 5–Mounting & Duct Lengths

NOTE: The blower and the adjoining duct (shown in the darker shaded areas) are not part of the burner assembly; they must be purchased and installed separately.



- Provide at least 3" (76 mm) clearance between burner and top, bottom and sides of the duct.
- Profile plates are not required for good burner operation, but uniform velocity must be maintained for full length of burner. If velocity is not uniform, use profile plates to correct it.

- Center the burner in the duct.
- Allow a minimum of 46" (1168 mm) from burner to nearest point of possible flame impingement at an input of 1,000,000 Btu/hr. (962 kW/m).
- Support the blower and motor independently of the burner.

Duct Lengths

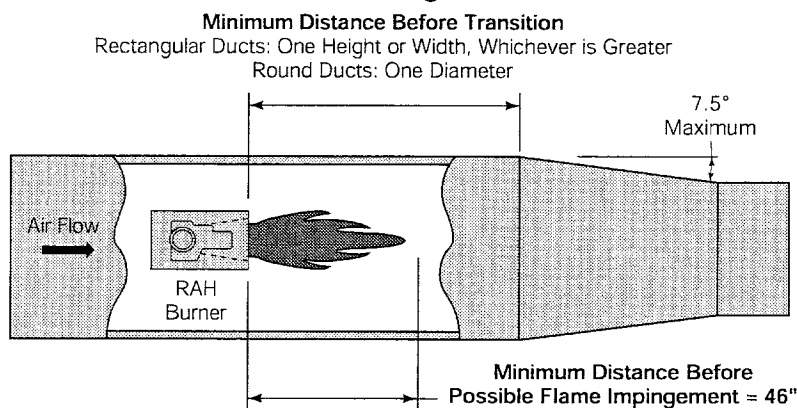

3.0 Duct Design and Burner Mounting

Duct Design	See Figure 5 for typical mounting arrangements and duct designs.
Support	The mounting brackets supplied with the burner are capable of supporting the weight of the burner. Support the blower and air manifold independently of the burner.
Air Manifold	The air manifold must be large enough to supply the required combustion air flow with minimum pressure drop. Do not use more than one 90° bend between the blower and the burner air inlet.
Valve Train Support	Support valve trains independently of the burner.
Gas Piping	Use flexible nipples to allow for thermal expansion of the burner.
Check Valve Piping	Gas flow through the check valve must be horizontal. See Figure 3.
Gas Piping Standards	Gas piping must comply with American National Standard entitled "National Fuel Gas Code"* (NFPA No. 54 or ANSI Z223.1), or must be acceptable to the authority having jurisdiction.
Wiring Standards	Electrical wiring must comply with the National Electric Code*, (NFPA Std. 70 or ANSI-CI 1981), or must be acceptable to the authority having jurisdiction.

*Available from:

National Fire Protection Association
 Batterymarch Park
 Quincy, MA 02269

American National Standard Institute
 1430 Broadway
 New York, New York 10018

4.0 Start-Up And Adjustment

Initial Settings

Adjust the linkage of the gas control valve so that when heat is called for, the valve is 10° from fully open, and when cooling is required, the valve is approximately 5° from fully closed.

Close all manual gas cocks.

With the pilot cock handle in the closed position, remove the top screw and turn the adjusting screw five turns out from fully closed. See Figure 6.

Start Blower

Start the combustion air blower on the burner. Check the rotation to make sure it is correct. If not, have a qualified electrician re-wire the blower for proper rotation.

Start Circulating Fan

Start the duct circulating fan.

Set Air Pressure Drop

Measure the air pressure drop across the burner as shown in Figure 7.

Adjust the blower damper until the air pressure drop is between 0.4" w.c. minimum and 1.0" w.c. maximum. For a given input, lower air pressure drops will produce a longer flame, and higher drops will produce a shorter flame.

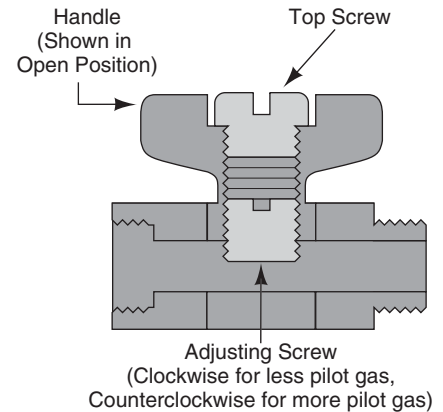
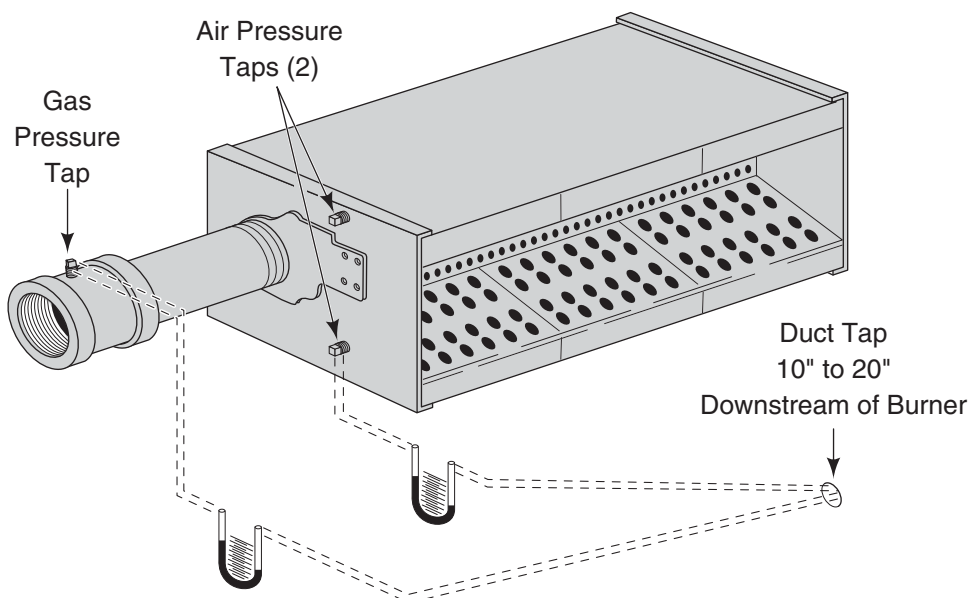

Figure 6 — Pilot Cock

Large Burners Only: Some models, such as the 640, 680, and 720 TAH-R burners, contain a butterfly valve in the check valve line as shown in Figure 8. On these models, after setting the air flow as described in the previous paragraph, measure the air pressure drop between the gas pressure tap and duct as shown in Figure 7. Gas flow must be off. Adjust the butterfly valve to produce an air pressure drop of 0.2" w.c.

Figure 7 — Pressure Measurement



4.0 Start-Up And Adjustment (continued)

Start Spark

Energize the ignition spark. **Do not touch the ignition rod, ignition wire, or transformer while the spark is energized, or you will get a shock.**

Set Pilot Flow

Open all pilot gas valves, including the handle of the pilot cock, Figure 6. The pilot should light.

Turn the pilot adjusting screw to produce a bushy blue flame that provides a flame monitoring signal strong enough to reliably open the gas shut-off valves.

Set Gas Flow

Measure the gas differential pressure as shown in Figure 7.

With the gas control valve at low fire, open all main gas valves. The burner should light with a stable, blue low fire flame that extends evenly down the burner length.

Drive the control valve to high fire and adjust the gas adjusting valve to produce a pressure drop that corresponds to the desired high fire rate, as shown in Fig. 1.

When setting high fire, be sure the flame does not impinge on anything downstream of the burner. To shorten the flame length for a given gas input, increase the air pressure drop as described above.

Figure 8–Butterfly in Check Valve Line

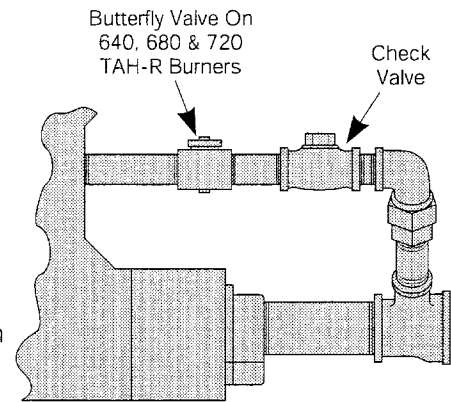

Check All Settings

Return the burner to low fire and check to be sure that the burner remains lit with a stable flame that extends down the burner length. Cycle the burner between low and high fire several times, checking pressure drops and flame lengths.

5.0 Routine Maintenance

Motor Lubrication

Oil the blower motor according to the manufacturer's instructions as printed on the motor label.

Ignition Plug/Flame Rod

Ignition plugs and flame rods wear out over long periods of normal burner operation. Eclipse recommends that the user keep at least one of each in stock at all times to prevent nuisance shutdowns.

6.0 Trouble-Shooting

Symptom	Cause	Check	Remedy
1. Burner does not start initially.	<ul style="list-style-type: none"> a) Air pressure switches not making. b) Faulty pressure switches. 	<ul style="list-style-type: none"> a) Check pressures in duct at location of switch connections. b) Check electrical portion of switch. 	<ul style="list-style-type: none"> a) Change pressure connections where a more positive pressure is present.
2. Burner kicks out shortly after start-up.	<ul style="list-style-type: none"> a) Low gas pressure switch set too high. 	<ul style="list-style-type: none"> a) Check low pressure switch setting. 	<ul style="list-style-type: none"> a) Reset
3. Pilot will not ignite on initial light-off.	<ul style="list-style-type: none"> a) Raw gas fed into pilot causing carbon hair on spark plug. 	<ul style="list-style-type: none"> a) Check spark plug for carbon hair; also check gap on plug (should be 3/64" - 3/32"). 	<ul style="list-style-type: none"> a) Adjust pilot gas cock by first screwing needle closed, then with transformer powered, open needle slowly 1/4 turn at a time.
4. Flame failure when burner goes to high fire.	<ul style="list-style-type: none"> a) Gas pressure to pilot regulator too high. b) Bolts which fasten pilot casting to burner are not tight enough. c) Pilot regulator not reacting fast enough to duct pressure changes. d) Check valve stuck open. e) Too much pilot gas. 	<ul style="list-style-type: none"> a) Check pilot gas pressure to regulator (should be 1 PSIG maximum). b) Check tightness of bolts. c) Check impulse line for possible dirt clogging; also check impulse line duct connection to determine if an effective pressure is being transmitted to regulator. 	<ul style="list-style-type: none"> a) Relocate pilot gas line or use second pilot regulator. b) Tighten bolts. c) Clean impulse line of any dirt particles and relocate duct connection to transmit maximum duct pressure. d) Clean check valve. e) Reduce pilot gas flow.
5. Flame failure when main burner returns from high to low fire.	<ul style="list-style-type: none"> a) Gas pressure to pilot regulator. b) Under-gassing pilot. 	<ul style="list-style-type: none"> a) See Check 4a. b) Check pilot regulator inlet and outlet gas pressures; also check pilot flame. c) See Check 4c. 	<ul style="list-style-type: none"> a) See Remedy 4a. b) Open needle on pilot adjusting cock slowly 1/4 turn at a time. c) See Remedy 4c.
6. Main flame too large at high fire.	<ul style="list-style-type: none"> a) Gas pressure too high at burner inlet. b) Combustion air pressure too low. c) Check valve stuck open. 	<ul style="list-style-type: none"> a) Check gas pressures. b) Check air pressure differential. 	<ul style="list-style-type: none"> a) Screw out on main gas pressure regulator. Adjust linkage on gas control valve to hold valve less than full open when at high fire. b) Open air shutter on makeup air blower. c) Clean check valve.
7. Main flame not extending beyond face of burner at high fire.	<ul style="list-style-type: none"> a) Air pressure differential too high. b) Burner not firing rated input. c) Burner gas holes plugged. 	<ul style="list-style-type: none"> a) Check air pressure differential between combustion air manifold and main duct. b) Check gas pressure differential. c) Check gas holes for dirt or lint. 	<ul style="list-style-type: none"> a) Close air shutter on makeup air blower. b) Screw in on main gas pressure regulator to provide more gas. c) Clean gas holes with #42 MTD drill. Clean air holes with #27 MTD drill.
8. Main flame long and yellow.	<ul style="list-style-type: none"> a) Velocity past burner lower than 500 FPM. b) Check valve stuck open. 	<ul style="list-style-type: none"> a) Check velocities and rotation of main circulating fan. 	<ul style="list-style-type: none"> a) Open shutter on makeup air blower. b) Clean check valve.



ECLIPSE COMBUSTION



Offered By:

Power Equipment Company
2011 Williamsburg Road
Richmond, Virginia 23231
Phone (804) 236-3800
Fax (804) 236-3882

www.peconet.com